



UNIQA REVOLUTION
DON'T COMPLICATE YOUR LIFE



UNIQA
R E V O L U T I O N

A UNIQUE AND INGENIOUS SOLUTION

European ErP legislation has changed the rules of the game, defining the minimum requirements to be met for products used for space heating and hot water production, in order to significantly reduce CO₂ emissions by 2020. According to this legislation, traditional boilers (non-condensing) with a sealed chamber can no

longer be placed on the market from September 2015.

In this scenario, Sime proposes Uniq Revolution, the class B boiler which already complies with the pollutant limits of 2018 and which is installed like a traditional boiler, since it does not require chimney pipework and condensate drainage.

2

EVERYONE KNOWS THAT SOMETHING IS
IMPOSSIBLE TO CREATE UNTIL SOMEONE COMES
ALONG WHO IS UNAWARE OF THIS AND INVENTS IT.

Albert Einstein

TECHNOLOGICAL BENEFITS

- Specific product for the replacement of traditional, sealed chamber boilers
- Without condensate drainage
- Installed with traditional flue
- Equipped with active recovery in heat pump



THE BOILER THAT SOLVES THE PROBLEM

Replacing a traditional boiler with a condensing one can be particularly costly because it requires the realisation of condensate drainage and, in some cases, pipework in the existing chimney, not suitable for low temperature fumes.

The costs of these interventions are

significant and are added to those of the purchase and installation of the generator.

Uniqua Revolution is the only product that is installed like a traditional boiler, while meeting the strict Ecodesign requirements of the ErP legislation.

4

CONDENSING BOILER

It requires condensate drainage and often chimney pipework

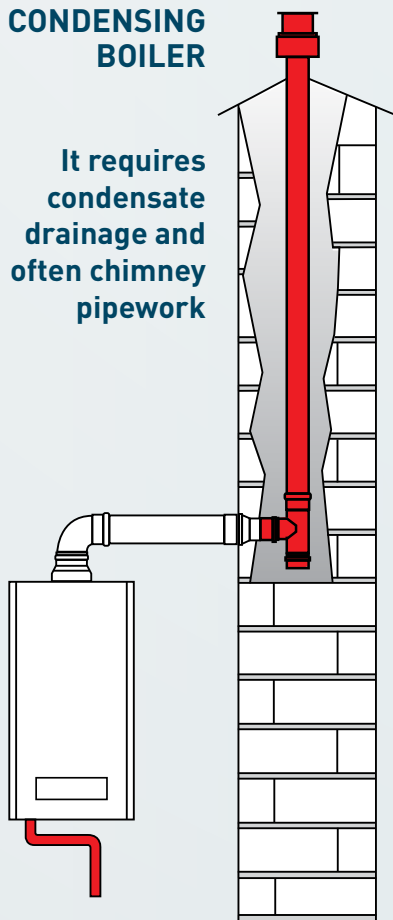

UNIQA REVOLUTION

It's installed like a traditional boiler

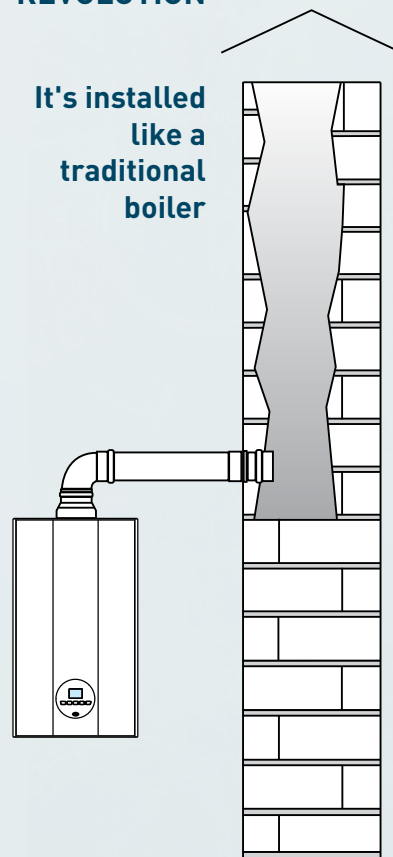

HOW IT WORKS

Uniqa Revolution features active recovery (booster) which increases its performance in accordance with the ErP requirements.

The heat transfer fluid receives heat from the air drawn from outside and conveyed in the 1st active recovery exchanger **1**. Then the active recovery motor **2** compresses the fluid and transfers the heat to the return water of the heating system in the 2nd active recovery exchanger **3**. Then the water passes through the low NOx burner **4**, heating up even more, and then through the boiler exchanger **5**.

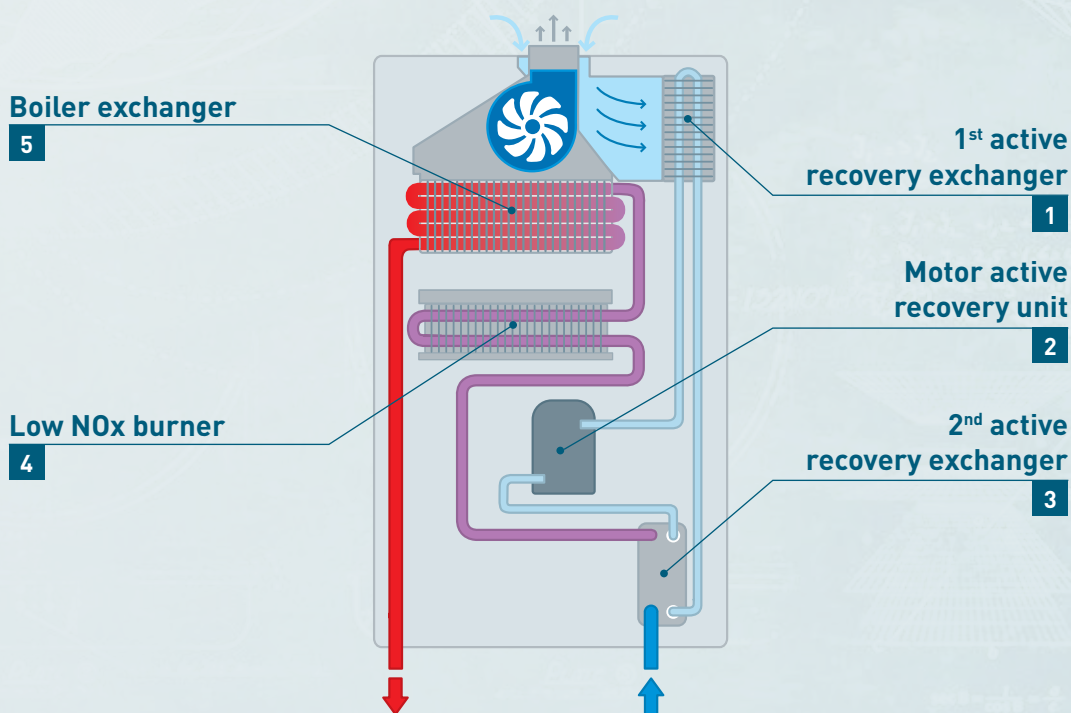

THE HEAT RECOVERY UNIT ALLOWS TO ACHIEVE SEASONAL PERFORMANCE IN HEATING COMPLYING WITH CLASS B, ACCORDING TO THE ErP LEGISLATION

UNIQA REVOLUTION IN DETAIL

6

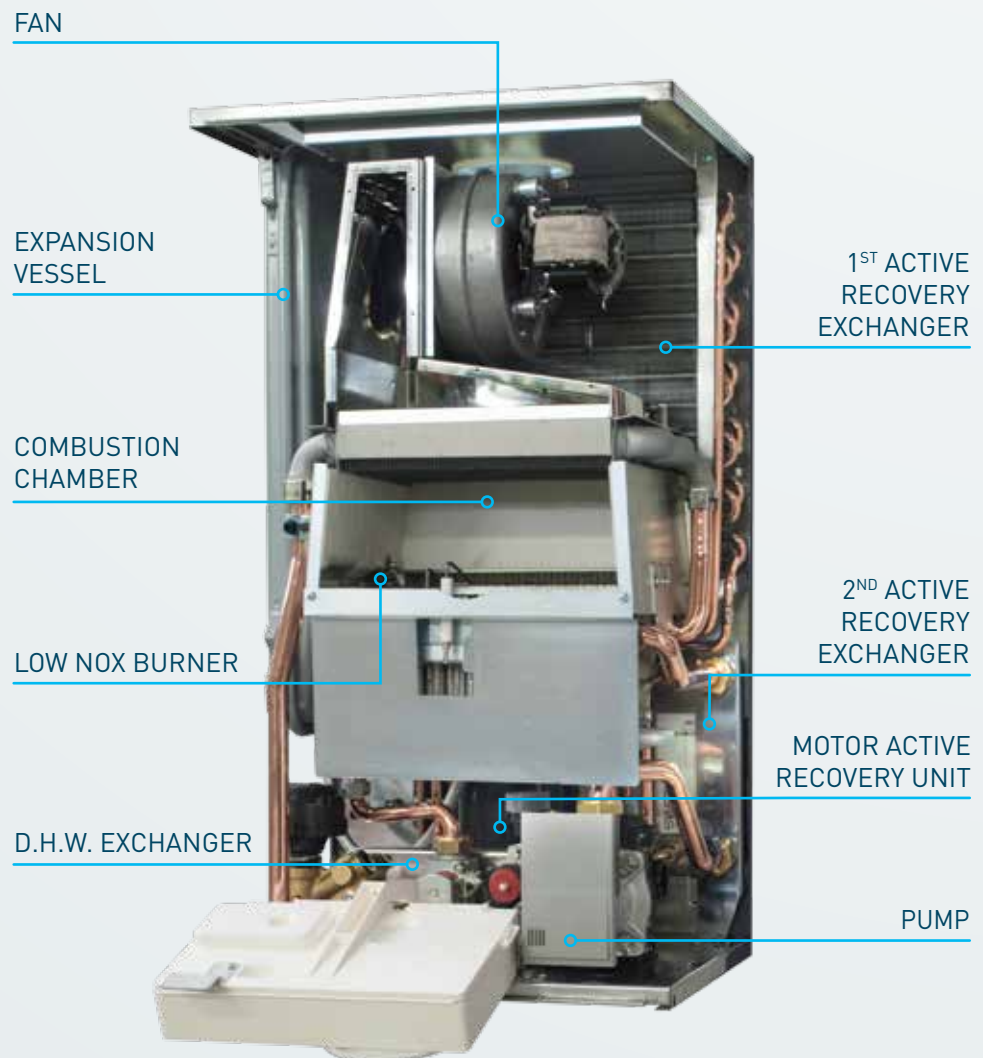

TECHNICAL FEATURES AND DIMENSIONS

		UNIQA REVOLUTION
Nominal thermal power (80-60°C)	kW	22,9
Reduced thermal power (80-60°C)	kW	8,9
Heating nominal heat flow	kW	24,5
Heating reduced heat flow	kW	10,0
Max useful yield (80-60°C)	%	93,4
Min useful yield (80-60°C)	%	89,2
Useful performance at 30% of the load	%	108,8
Central heating energy efficiency class		B
D.H.W. energy efficiency class		A
D.H.W. energy efficiency	%	87
Domestic hot water load profile		XL
Central heating sound power	dB(A)	54
Maximum absorbed electric power	W	450
Electric protection degree	IP	X5D
Central range	°C	20÷80
Boiler water content	l	3,35
Max operating pressure	bar	3
Max operating temperature	°C	85
Central heating expansion vessel capacity	l	8
Central heating expansion vessel pressure	bar	1
Domestic hot water range	°C	10÷60
D.H.W. nominal heat flow	kW	24,5
Specific sanitary flow rate ΔT 30°C (EN 13203)	l/min	10,6
Continuous sanitary flow rate ΔT 25/35°C	l/min	12,9/9,2
D.H.W. minimum flow rate	l/min	2
D.H.W. pressure (max/min)	bar	7,0/0,5
Max flue gas temperature	°C	106
Min flue gas temperature	°C	75
Max \varnothing 60/100 horizontal length*	m	2,5
Max horizontal twin pipe length*	m	10+10
NOx class		6 (< 56 mg/kWh)
Weight	kg	45

* horizontally with a 90° curve

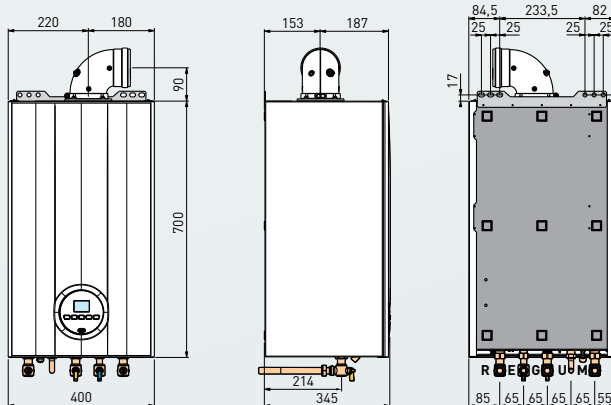

CONNECTIONS

R Central heating return	G 3/4"
M Central heating flow	G 3/4"
G Gas supply	G 3/4"
E D.H.W. inlet	G 1/2"
U D.H.W. outlet	G 1/2"



cod. 3952119A [I] - www.sime.it